



Cold
water

GWF



Meistream

Bulk water meters
for cold water up to 50°C
DN 50, 65, 80, 100, 125, 150, 200, 250, 300

Your benefits

- Measurement of low flow rates:
Increased cost effectiveness
- Removable measuring insert:
Retrofittability and replaceability guaranteed
- One measuring insert for various bodies:
Lower storage costs

Application

- Measurement of high flow rates, e.g.
 - Downstream of pumps or at transfer points
 - Reservoir inflows and outflows
 - Industrial processes
- Measurement of low flow rates during offpeak periods
- Measuring of
 - Desalinated / demineralized water
 - Caustic soda up to 20%
 - Saline water up to 10%
 - Chlorinated water up to 1%
 - Glycol-water solutions up to 30%
 - Caustic solutions up to pH value 9

Features

- Universal installation position
- No straight flow section required before the meter
- Register can be turned through 355°
- Maximum operating pressure PN 16 bar
- Temperature up to 50°C
- Rotor is hydrodynamically, radially, and axially balanced
- Available in the standard installation lengths for WS and WP meters
- Powder coating provides optimum corrosion protection
- Non-ferrous metal design up to PN 16 bar
- SVGW certification
- **CE** Conformity according to the European Measuring Instrument Directive (MID)
- Flood-proof standard pulser register (IP68) with a port for one Opto-OD-Pulser and provision for a HRI-Mei pulser

Options

- Flood-proof GWFcoder® register (IP68) with IEC or M-Bus interface and 5m cable and provision for a HRI pulser
- High-pressure series up to PN 40 bar
- High-resolution pulse generator HRI-Mei
 Documentation: HRI-Mei - EPe10222
- High-resolution pulse generator Opto OD
 Documentation: Opto-OD-Pulser - EPe10205

Technical Data

Nominal diameter ¹⁾	DN	mm	50	50	65	65	80	80	100	100	125	150	150	200	250	300
Nominal pressure ²⁾	PN	bar	16	16	16	16	16	16	16	16	16	16	16	16	16	16
Nominal flow rate	Q ₃	m ³ /h	50	50	70	70	120	120	230	230	250	450	450	800	1250	1400
Overload flow rate (few minutes)	Q ₄	m ³ /h	90	90	120	120	200	200	300	300	350	600	600	1200	1600	2000
Transitional flow rate ±2%	Q ₂	m ³ /h	0,4	0,4	0,63	0,63	0,51	0,51	0,81	0,81	1,02	1,6	1,6	4,03	6,3	16
Minimum flow rate ±5%	Q ₁	m ³ /h	0,15	0,15	0,2	0,2	0,2	0,2	0,3	0,3	0,5	0,8	0,8	2	3,5	9
Temperature		max. °C	50	50	50	50	50	50	50	50	50	50	50	50	50	50

Dimensions and weights																
Overall length	L	mm	200	270 ³⁾	200	300	225	300	250	360	250	300	500	350	450	500
Height ⁴⁾	H	mm	120	120	120	120	150	150	150	150	160	177	177	214	238	264
Height	h	mm	73	73	85	85	95	95	105	105	118	135	135	162	194	226
Dismantling height of measuring unit ⁴⁾	g	mm	200	200	200	200	270	270	270	270	280	356	356	449	474	499
Meter weight		app. kg	7,8	9,6	10,1	12	14,2	16,3	18,2	20,2	20,7	35,9	35,9	56,9	79,4	103,8
Measuring unit weight		app. kg	1,5	1,5	1,5	1,5	3,2	3,2	3,2	3,2	3,2	5,9	5,9	9,6	9,6	9,6
Body weight		app. kg	6,3	8,1	8,6	10,5	11	13,1	15,0	17,0	17,5	30	30	47,3	69,8	94,2

¹⁾Nominal size DN 40 upon request

²⁾High-pressure series PN 40 upon request

³⁾Also available with 300 mm body length

⁴⁾The dimension g and H increase by 22mm if a HRI-Mei impulse generator and cover are installed

MID certification data																
Nominal flow rate	Q ₃	m ³ /h	40	40	63	63	100	100	160	160	160	400	400	630	630	1000
Temperature		max. °C	50	50	50	50	50	50	50	50	50	50	50	50	50	50
Horizontal measuring range			R160	R160	R160	R160	R315	R315	R315	R315	R250	R400	R400	R250	R125	R63
Vertical measuring range			R100	R100	R100	R100	R125	R125	R160	R160	R125	R200	R200	R250	R100	R63
Standard marking			R100	R100	R100	R100	R100	R100	R100	R100	R100	R100	R100	R100	R100	R63

Dimension Diagram

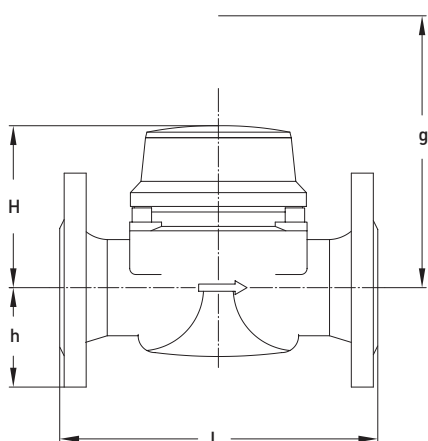

Materials

Body:	Cast iron
Measuring unit:	Plastic
Rotor:	Plastic
Other materials:	Brass / non-rusting steel

Measurement error curve

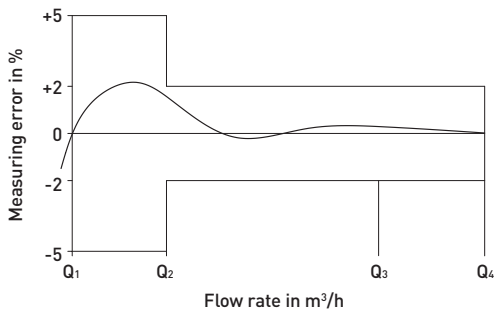

Typical Head Loss Curve

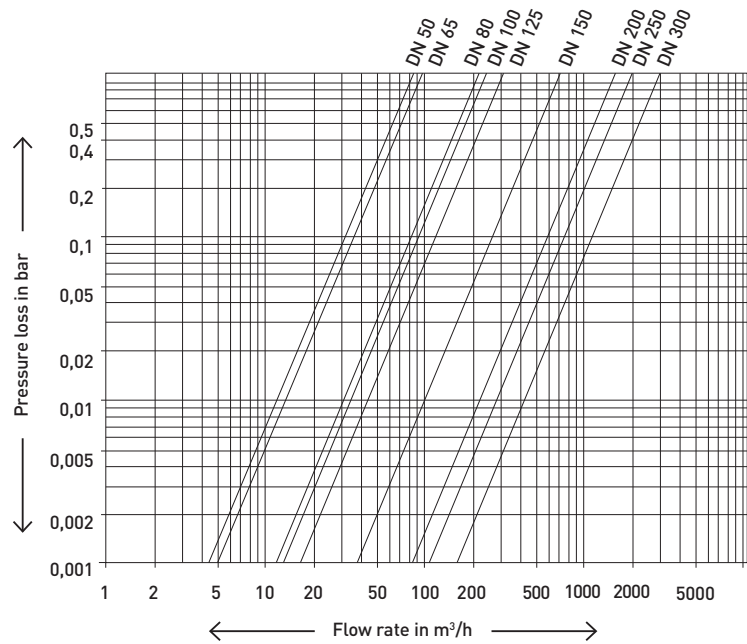

Installation

Pipeline: horizontal —
vertical |
diagonal /

Meter head: upwards ↕
sideways ↔



Commission

When commissioning the meter the measuring section must be filled slowly (bleed slowly).

Dial

DN 50 – DN 125

DN 150 – DN 300

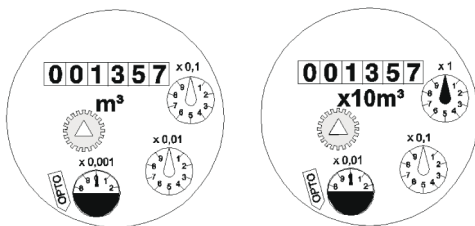

Nominal size	DN	50–125	150–300
Smallest reading	m ³	0,0005	0,005
Maximum register reading	m ³	1'000'000	10'000'000

Pulse values HRI-Mei Pulser

Meter sizes	DN 50...125 1 Pulse = ...Liter	DN 150...300 1 Pulse = ...Liter
Meistream	10 100	100 1000

Pulse values Opto-OD-Pulser

Meter sizes	DN 50...125 1 Pulse = ...Liter	DN 150...300 1 Pulse = ...Liter
Meistream	Opto OD 01 Opto OD 03	1 10
	1 10	10 100

GWF MessSysteme AG
Obergrundstrasse 119
6005 Lucerne, Switzerland

T +41 41 319 50 50
F +41 41 310 60 87
info@gwf.ch, www.gwf.ch

Technical support:
T +41 41 319 52 00, support@gwf.ch

printed in
switzerland

Subject to modification, 09.08.2019 – EPe10220