



MTWcoder[®] MP

Multijet meter
with M-Bus interface EN 13757-2
for warm water up to 90°C
DN 15, 20, 25, 32, 40, 50

Your benefits

- Mechanical roller register with 1-litre-resolution:
Efficient consumption monitoring in energy data management
- Transfer of the effective meter reading:
No data loss and guaranteed security of the billing data
- Register without batteries:
No service life restriction
- Robust, high grade wear resistant materials:
Excellent measuring stability and reliability
- Measurement of low flow rates:
Increased cost effectiveness

Application

- Residential consumption monitoring of water consumption within an entire building
- For nominal flow rates up to 25m³/h
- Water meter with M-Bus data communication

Options

- Flanged variant PN 16 or PN 25
- NPSM threaded connection (only for horizontal housing)

Features

- Multijet impeller wheel, super dry-dial, magnetic coupling
- 8 dial resolution with 3 comma place
- Register can be turned for best readout position
- Maximum operation pressure PN 16 bar (Flanged PN 25 bar)
- Maximum operating temperature 90°C
- Horizontal or vertical installation (MTW-V...)
- Flanged configuration only for horizontal installation
- High grade wear resistant and corrosion proof materials
- Inlet strainer
- KTW and W270 Certification
- **CE** Conformity according to European Measuring Instruments (MID)
- Serial M-Bus interface to EN 13757-2/3
- Power is provided from the M-Bus central
- Connecting cable, standard length 1,5m

GWFcoder[®]-Technology

The 2nd generation

The well-established GWFcoder[®]-system reads the absolute mechanical register value precisely and reliably and provides the data through standardized interfaces. The number wheels with three various long, asymmetrically arranged slots are being scanned through light pipes which are connected to five light emitting diodes (LED). Thus, the exact position of each number wheel can be detected and the encoded absolute register read can be transmitted as part of the M-Bus protocol. This functioning principle is patented by GWF. The GWFcoder[®]-interface provides an incomparably higher level of information compared to meters with pulse output.

GWF enhanced the reliable technology in its 2nd generation, so that 8 instead of 5 number wheels are being scanned and therefore a resolution of 1 liter is possible.

□ Documentation: HRE-CH - EPe10125

Technical Data

Execution			MTWcoder® MP (horizontal)							MTWcoder® MP-VS or -VF (vertical) ¹⁾			
Nominal diameter	DN	mm	15	20	25	25	32	40	50	20	25	32	40
Operating pressure	PN	bar	16	16	16	16	16	16	16	16	16	16	16
Operating pressure (flanged)	PN	bar	-	25	25	25	25	25	25	-	-	-	-
Connection thread on meter	G...B	Inch	¾	1	1¼	1¼	1½	2	2⅜	1	1¼	1½	2
Connection thread on coupling	R...	Inch	½	¾	1	1	1¼	1½	2	¾	1	1¼	1½
Nominal flow rate	Q ₃	m³/h	2,5	4	6,3	10	10	16	25	4	6,3	10	16
Maximum flow rate	Q ₄	m³/h	3,125	5	7,875	12,5	12,5	20	31,25	5	7,875	12,5	20
Transitional flow rate ±3%	Q ₂	l/h	40	80	126	200	200	320	500	80	126	200	320
Minimum flow rate ±5%	Q ₁	l/h	25	50	78,75	125	125	200	312,5	50	78,75	125	200
Temperature		max. °C	90	90	90	90	90	90	90	90	90	90	90
Measuring range			R100	R80	R80	R80	R80	R80	R80	R80	R80	R80	R80

Dimensions and weights			MTWcoder® MP (horizontal)							MTWcoder® MP-VS or -VF (vertical) ¹⁾			
Length without couplings	A	mm	165	220 ²⁾	260	260	260	300	300	105	150	150	200
Length with couplings		mm	239	312	352	352	372	432	452	197	242	262	332
Meter height with lid	B	mm	119	125	135	135	135	160	174	-	-	-	-
Meter height with lid from pipe centre line	C	mm	84	85	91	91	91	114	117	-	-	-	-
Meter depth with lid	D	mm	-	-	-	-	-	-	-	148	169	183	226
Meter depth with lid from pipe centre line	E	mm	-	-	-	-	-	-	-	130	143	156	190
Installation depth with lid from pipe centre line	W	mm	48	48	50	50	50	68	76	48	49	51	70
Meter height with open lid	G	mm	167	173	183	183	183	208	222	-	-	-	-
Length with flanges PN 16/25		mm	-	190	260	260	260	300	300 ³⁾	-	-	-	-
Height with flanges	H	mm	-	146	156	156	165	197	209	-	-	-	-
Flange external dimension ⁴⁾		mm	-	105	115	115	140	150	165	-	-	-	-
Hole circle diameter ⁴⁾		mm	-	75	85	85	100	110	125	-	-	-	-
Number of screws ⁴⁾		Pcs.	-	4	4	4	4	4	4	-	-	-	-
Weight without couplings		app. kg	1,7	2,1	2,6	2,6	2,7	5,4	6,7	-	-	-	-
Weight without couplings MTW-VS		app. kg	-	-	-	-	-	-	-	1,9	3,0	3,0	6,0
Weight without couplings MTW-VF		app. kg	-	-	-	-	-	-	-	2,0	3,4	3,7	7,3
Weight with couplings		app. kg	1,9	2,3	3,0	3,0	3,3	6,4	8,7	-	-	-	-
Weight with couplings MTW-VS		app. kg	-	-	-	-	-	-	-	2,1	3,4	3,6	7,0
Weight with couplings MTW-VF		app. kg	-	-	-	-	-	-	-	2,2	3,8	4,3	8,3
Weight with flanges		app. kg	-	3,8	4,7	4,7	6,3	8,1	11,5	-	-	-	-

¹⁾ -VS = vertical riser / -VF = vertical down pipe

²⁾ Also supplied in length 190mm

³⁾ Also supplied in length 270mm

⁴⁾ DIN EN 1092-2

Dimension Diagram

MTWcoder® MP
with meter lid

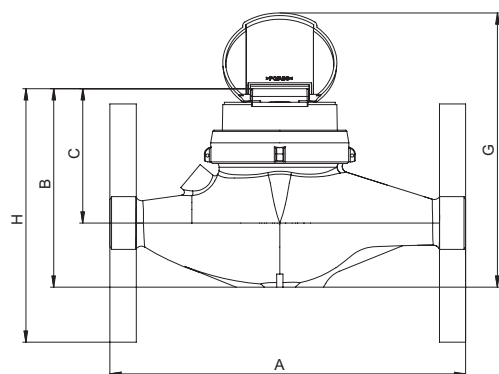

MTWcoder® MP-V...
with meter lid

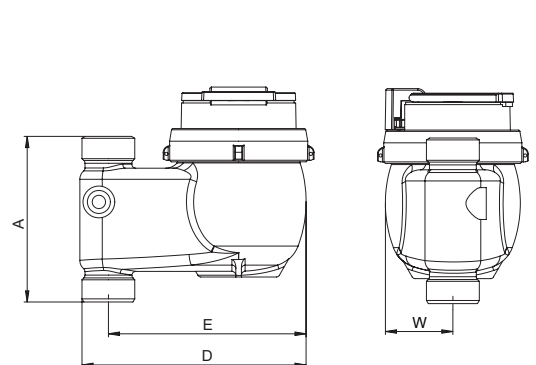

Materials

Housing with screwed connection:	UBA Brass (DIN 50930-6)
Housing with flanged connection:	Cast iron
Sealing plate:	UBA Brass (DIN 50930-6)
Impeller / measuring insert:	High grade synthetic materials
Bearing:	Hard metal, Sapphire, Chrome nickel steel
Seal material:	EPDM

Measuring error curve

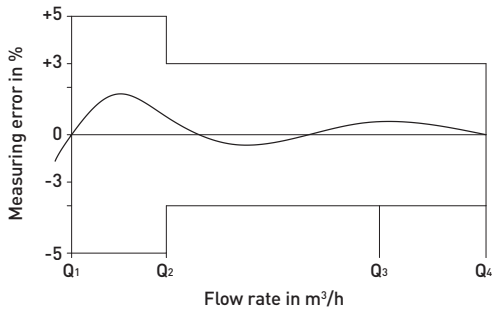

Typical Head Loss Curve

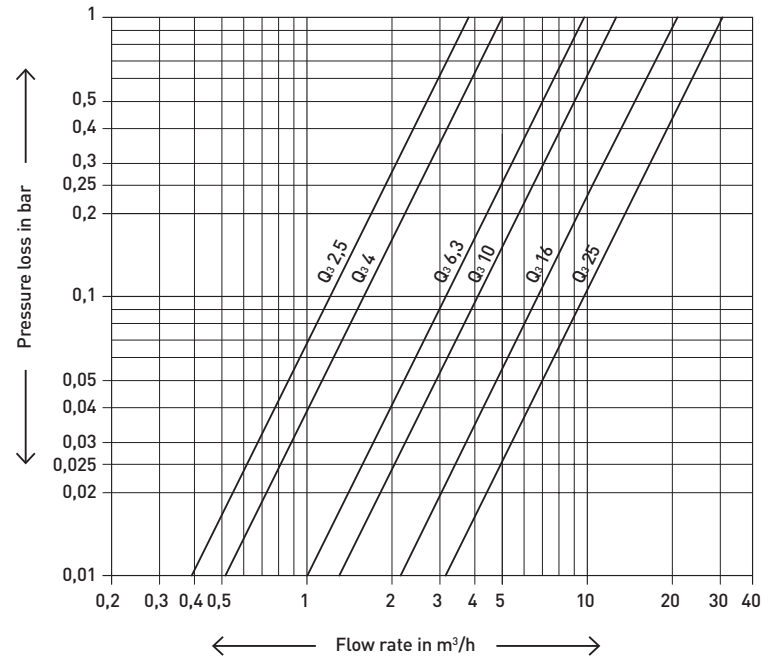

Installation

Pipeline:	horizontal	—
	vertical	
Meter head:	upwards	↑

Installation Requirements

The meter must be installed so that the type plate is always horizontally positioned, facing upwards (do not tilt).

Documentation: GWF water meters - BAdfei10207

GWF MessSysteme AG
Obergrundstrasse 119
6005 Lucerne, Switzerland

T +41 41 319 50 50
F +41 41 310 60 87
info@gwf.ch, www.gwf.ch

Technical support:
T +41 41 319 52 00, support@gwf.ch

.....
printed in
switzerland

Subject to modification, 22.08.2018 – EPe20130